

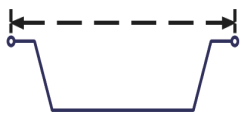

Specification Sheet – Product Code 3050

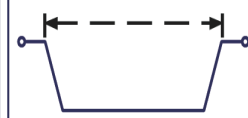
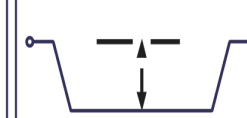
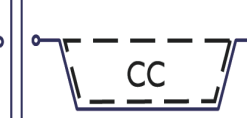

 top out (mm)	 top in (mm)	 base (mm)	 height (mm)	 capacity (cc)
105	95	73	47	252

Specifications	
Type	Basin Foil
Flange Style	Vertical Flange
Base Style	Plain
Material	Plain Aluminium Foil Container Strip – H24
Gauge (micron)	45
Metal Weight/1000 (kgs)	3.27 (+/- 8% tolerance)
Quantity Per Case	2,000
Quantity per Layer / Pallet	4 Cases 16 Cases
Carton weight gross(kgs)	8.67
Outer carton dimensions(mm)	597 X 485 X 450